

## Trackside XML interface module

Standard Q-style (BR930) mounting

Ethernet, GSM/GPRS, RS485 Coms

Low 2W power consumption

Large 2GB storage

High precision clock

Analogue & digital inputs as standard

Low cost stand-alone RCM unit

Create Master-Slave networks with the SA380TX

Up to 40% system cost savings

The TX-L is the latest addition to the SA380 family of precision data acquisition systems designed for the unique railway environment. It shares much of the design philosophy of the SA380 and SA380TX with all the electrical isolation, rugged form and ease of installation and use that is now expected of these products.

The TX-L is designed to connect any type of trackside asset to server-based supervisory and diagnostics systems, such as:

- DC Track circuits
- Point machines
- Digital AF track circuits
- Insulation monitors

The unit features two analogue and four digital inputs as standard. In many monitoring situations, this is all that is required and so the lowest-cost version of the unit can be used, without having to pay for additional input cards.

The "L" in TX-L stands for "lean" - part count has been reduced by 30% compared to the TX, bringing together higher reliability, lower environmental impact and lower cost. Despite these economies the TX-L boasts improvements, such as greater sampling accuracy.



### As a slave unit

Up to 7 TX-L units can be networked with a master SA380TX using a multi-drop RS485 network.

- Single twisted pair communication cable
- Total Network length up to 1,200m
- Can be installed in 8 different location cases
- All configuration conducted on the Master
- Single modem and SIM for the whole network
- Up to 78 analogue channels
- Up to 166 digital channels
- **Up to 40% system cost savings**

### As a stand-alone unit

When fitted with a modem or Ethernet card the TX-L can act as a low-cost alternative to the SA380TX for RCM applications.

- Acquisition methodology identical to the SA380TX
- Configuration, data retrieval and real-time diagnostics via intuitive Windows based software.
- Logger status visible "at a glance" via eight LED's
- Compatible with Network Rail's MIMOSA XML protocol
- Compatible with MPEC's RailDAQ binary protocol
- 2 Analogue and 4 digital inputs provided as standard
- Expandable to up to 10 analogue or 20 digital inputs
- **Up to 40% system cost savings**



Mounts on standard location case relay bars

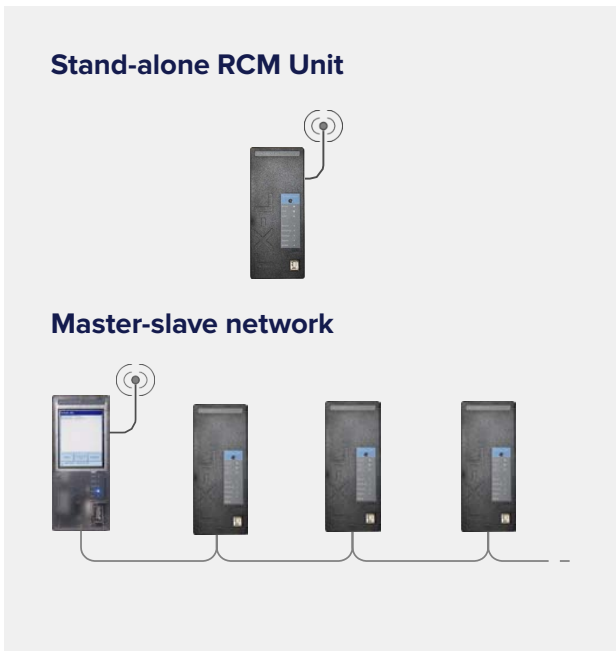

### System data flow

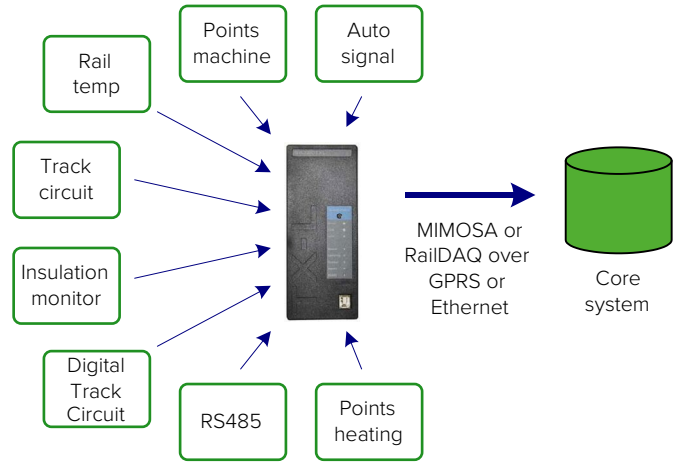

### Technical specifications

#### General

Fixings	To fit standard Q style/BR930 relay rack
Size	135 x 56 x 175mm - 1 relay position
Temperature range	-25°C - +70°C

#### Digital inputs

	4, 12 or 20
Type	Volt-free relay contacts
Isolation to earth	10MΩ at 1,000V DC min
Max differential DC voltage	55V

#### Analogue inputs

	0, 4 or 8
Range	4-20mA
Resolution	10 bit
Sampling rate	1000Hz max
Isolation to earth	10MΩ at 1,000V min

#### Power supply

	90-264Vac
Isolation to earth	10MΩ at 1,000V min
External PSU outputs	24V 2W per analogue channel 5V, 12V, 15V aux supplies optional

#### Processor

	Dual 80MHz MIPS 2GB non-volatile storage
--	---

#### Comms

	Isolated RS485 Ethernet GSM /GPRS modem
--	---

#### LEDs

	8 status LEDs
--	---------------

### Rear panel layout

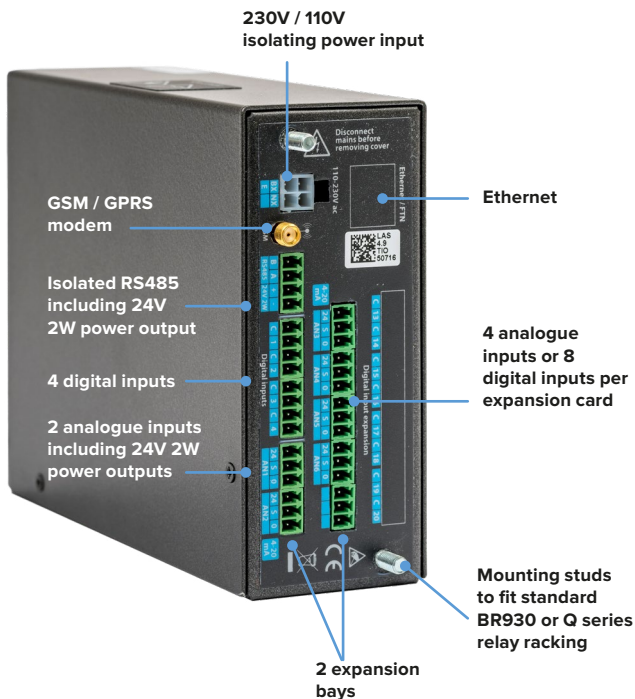

### Example monitoring connections

Four digital and two analogue inputs are provided in the base unit. There are two expansion slots; these can be filled with either analogue or digital cards or a mixture of the two. Analogue cards have four inputs each and digital cards have eight. For example, an SA380TX-L with one digital card and one analogue card would have a total of 12 digital and 6 analogue inputs.

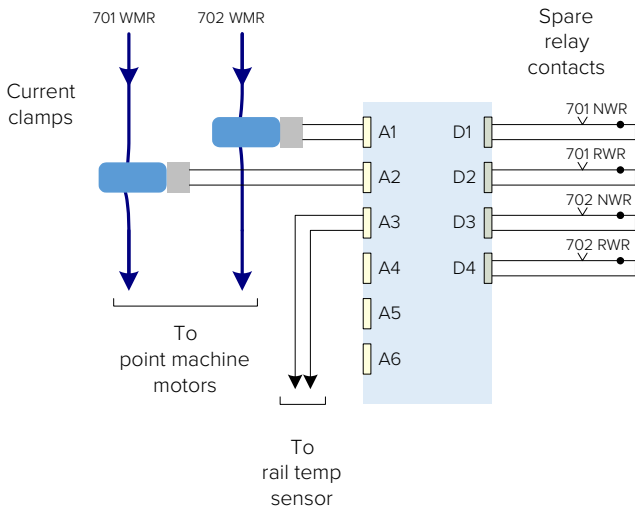

### Configuration and interrogation software

All interrogation and configuration is undertaken using "dPanel" - An easy to use PC based software package that can connect to the TX-L over air, via Ethernet, or alternatively using a standard USB cable.

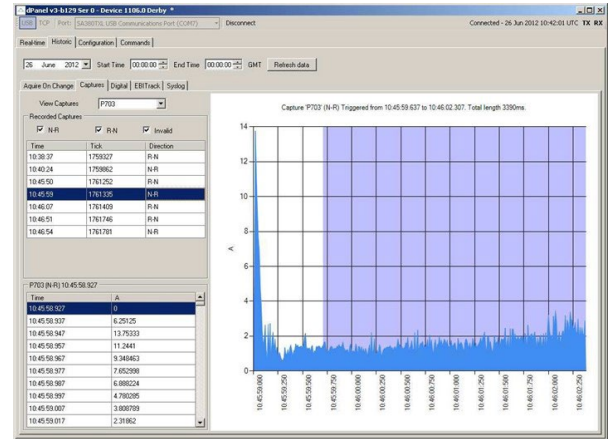

**For more information please contact:**  
MPEC Technology Ltd, 6 Pinnacle Way  
Pride Park, Derby, DE24 8ZS

**Tel:** 01332 363 979  
**Email:** enquiries@mpec.co.uk  
**Web:** www.mpec.co.uk